

CARB toroidal roller bearings, cylindrical and tapered bore

Principal dimensions			Basic load ratings		Speed ratings		Designation	
d	D	B	dynamic C	static C0	Reference speed	Limiting speed	* SKF Explorer bearing	** Check availability
mm			kN		r/min		-	
220	340	118	1930	3250	-	200	C 4044 K30V *	**

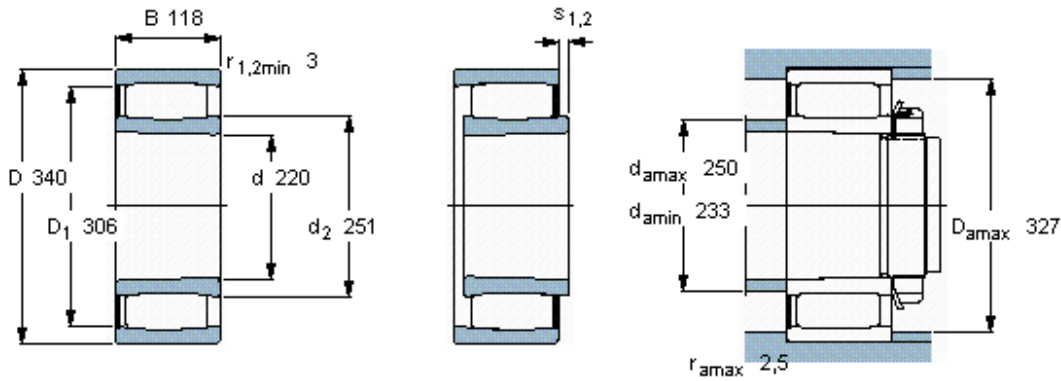

Tapered bore, taper
1: 30

Axial displacement s_1	20	
Axial displacement s_2 (retaining ring side)	10,1	
Misalignment factor k_1	0,115	
Operating clearance factor k_2	0,095	